

# Switching Power Supply Specifications

*Model Name : HPS-300-101*

*Version :*

*Issue Date :JUL,31,2000*

---

## Table of Contents

### **1. General**

1.1 Scope

### **2. Input Characteristics**

2.1 Input Voltage

2.2 Input Frequency

2.3 Max. Input AC Current

2.4 Inrush Current

2.5 Efficiency

### **3. Output characteristics**

3.1 Normal Operation Output

3.2 Remote On/Off controlled mode

3.3 Regulation

3.4 Rise Time

3.5 Hold-up Time

### **4. Protection**

4.1 Input Protection

4.2 Output Protection

### **5. Start Stability**

5.1 No Load Start

5.2 Cold Start

### **6. Environments**

6.1 Temperature and Humidity

6.2 Altitude

6.3 Vibration and Shock

# Switching Power Supply Specifications

*Model Name : HPS-300-101*

*Version :*

*Issue Date :JUL,31,2000*

---

## **7. Conducted EMI**

## **8. Product Safety**

- 8.1 Safety Requirement
- 8.2 Leakage Current
- 8.3 Insulation Resistance
- 8.4 Dielectric Voltage Withstand
- 8.5 Certificate and Report

## **9. Power Good Signal**

## **10. MTBF**

## **11. Burn-In**

- 11.1 Input Voltage
- 11.2 Test Condition

## **12. Mechanical Specification**

- 12.1 Outline Dimension
- 12.2 Weight
- 12.3 Pin Assignment

# Switching Power Supply Specifications

Model Name : HPS-300-101

Version :

Issue Date :JUL,31,2000

---

## 1. General

### 1.1 Scope

This specification defines the general design and performance requirements for HPS-300-101 switching power supply .This power supply can meet the Energy Start computer requirement specified by Environment Protection Agency of America. It also supports remote On/Off control function.Standby voltage and 3.3VDC output which will be the major trend for power supply in future.

## 2. Input Characteristics

### 2.1 Input Voltage

Nominal Voltage	Voltage Variation Range
-----	-----
115 Vrms	90 - 132 Vrms
230 Vrms	180 - 264 Vrms

\* The power supply is designed to operate in two specified voltage range depending upon outside manual input voltage switch selected. Unless specified the HPS-300-101 shall be set at 230Vac.

### 2.2 Input Frequency

Nominal Frequency	Frequency Variation Range
-----	-----
50/60 Hz	47 Hz to 63 Hz

\* Waveform harmonic distortion will be less than 5%.

\* The power supply must operate at above frequency with both 90-132/180-264 Vrms input voltage range.

### 2.3 Max. Input AC Current

Max. Input Current	Measuring Range
-----	-----
7.0 A	90-132 Vrms
4.0 A	180-264 Vrms

# Switching Power Supply Specifications

Model Name : HPS-300-101

Version :

Issue Date : JUL,31,2000

## 2.4 Inrush Current

Less than the ratings of its critical components (Including bulk rectifiers, fuses and surge limiting device).

## 2.5 Efficiency

HPS-300-101 provides an efficiency of 65 % minimum when measured at full load under 115V/60Hz and 230V/50Hz. condition.

## 3. Output characteristics

### 3.1 Normal Operation Output (LABEL SPEC)

Output Voltage	Load MIN	Range MAX	Regulation	Ripple&Noise Peak-to-Peak Max.	Ripple Peak-to-Peak Max.
1. +5V	2.0A	30.0A	+5% ~ -5%	100 mV	50 mV
2. +12V	0.5A	12.0A	+5% ~ -5%	200 mV	120 mV
3. -5V	0.0A	0.5A	+10% ~ -10%	200 mV	100 mV
4. -12V	0.0A	0.5A	+10% ~ -10%	200 mV	120 mV
5. +5Vs	0.0A	1.0A	+5% ~ -5%	100 mV	50 mV
6. +3.3V	0.5A	16.0A	+5% ~ -5%	100 mV	50 mV

**\*.+5V & +3.3V combined load should not exceed 180W**

#### NOTE:

1. DC +12V output should provide 14A surge for 15 seconds. And this regulation should be within +10%~-10%, noise & ripple should not exceed 200mV
2. Noise test should be measured with 20 MHz bandwidth frequency oscilloscope. The output terminal shall add a tantalum capacitor of 10uF in parallel with a ceramic capacitor of 0.1uF.
3. Regulation should cover A +/-20% dynamic output current changed within the static limit of para 3.1 for any one of combination of levels at frequency less than 1KHz

# Switching Power Supply Specifications

Model Name : HPS-300-101

Version :

Issue Date : JUL,31,2000

---

## 3.2 Remote On/Off Controlled mode

When AC power present, the power supply shall be in save mode operation and +5V S.B shall within its regulation window. When there comes a TTL "L" signal inserted, the power supply shall be on. When TTL signal "H" is inserted the power supply shall be off.

TTL level "H" 3.0V - 5.5V

"L" 0.0V - 0.8V

## 3.3 Regulation

The cross regulation defined as follows, the output regulation should be within the specified range.

Load	SYM	+5V	+3.3V	+12V	-5V	-12V
ALL Max.	HLHHH	30.0A	0A	12.0A	0.5A	0.5A
ALL Min.	LLLLL	2.0A	0.5A	0.5A	0.0A	0.0A
+5V Middle others Min	MLLLL	10.0A	0.5A	1.0A	0A	0A
+5V Middle others Max.	MHHHH	5.0A	16.0A	12.0A	0.5A	0.5A
ALL Max.	HLHHL	25.0	16.0	10.0	0.5	.05

## 3.4 Rise Time

DC output rise time is less than 100 mS at nominal line and full load.

## 3.5 Hold-up Time

DC +5V output maintains at least 16mS after power off which hold within para 3.1.

# Switching Power Supply Specifications

*Model Name : HPS-300-101*

*Version :*

*Issue Date :JUL,31,2000*

---

## 4. Protection

### 4.1 Input Protection

In primary circuit of the power supply , a protected fuse is inserted. Only internal fault of the power supply will cause the fuse blown. Any overload or short circuit at DC output will keep from fuse brown or fire hazard.

### 4.2 Output Protection

#### 4.2.1 Over Voltage Protection

The +5V/+12V DC output are protected against the over voltage condition . Maximum value can't be over 6.8V at 5V terminal and 15.6V at 12V.

#### 4.2.2 Over Power Protection

The power supply can be used electronic circuit to limit the output current against exceeding 50% of surge output power or protected against excessive power delivery since short circuit of any output or over total power at nominal line.

#### 4.2.3 Short Circuit Protection

Short circuit placed on any DC output will shut down all DC outputs and latch.

# Switching Power Supply Specifications

Model Name : HPS-300-101

Version :

Issue Date : JUL,31,2000

---

## 5. Start Stability

### 5.1 No Load Start

When power is applied to HPS-300-101 with no load connected or under minimum load connected, neither damage to power supply nor hazards to users will occur.

### 5.2 Cold Start

The power supply shall operate properly when first applied after 8 hours storage in 10°C environment.

## 6. Environments

### 6.1 Temperature and Humidity

#### 6.1.1 Operating

Temperature 10 to 50 °C

Relative Humidity 20 to 90 %

#### 6.1.2 Storage

Temperature -40 to 60 °C

Relative Humidity 20 to 95 % noncondensing

### 6.2 Altitude

The power supply can operate normally at any altitude between 0 to 8000 feet.

### 6.3 Vibration and Shock

Sweep and resonance search for each of X,Y,Z, axis at the sweep.

RATE of 1/OCTAVE/Min.

Frequency	Duration	Amplitude
5 - 20 Hz	15 minutes	0.38 mm
20 - 250 Hz	15 minutes	0.25G

# Switching Power Supply Specifications

*Model Name : HPS-300-101*

*Version :*

*Issue Date :JUL,31,2000*

---

## 7. Conducted EMI

The power supply will comply with FCC DOCKET 20780, Part 15 Class B limit for 115Vac input, FTZ 243 Class B for 230 Vac input and VCCI CLASS 2 requirement.

## 8. Product Safety

### 8.1 Safety Requirement

The power supply will be recognized under UL Standard 1950 without D3 deviation, certified with CSA standard C22.2 No.234-M90 safety requirements, and type approval with IEC publication 950 with A11 amendments.

### 8.2 Leakage Current

The AC leakage current is less than 3.5mA when the power supply connect to 254Vac/50Hz

### 8.3 Insulation Resistance

The insulation resistance should be not less than 30M ohm after applying of 500VDC for 1 minute.

### 8.4 Dielectric Voltage Withstand

The power supply shall withstand for 1 minute without breakdown the application of a 60Hz 1500V AC voltage applied between both input line and chassis (20mA DC cut-off current). Main transformer shall similarly withstand 3000Vac applied between both primary and secondary windings for a minimum of one minute.

### 8.5 Certificate and Report

EMC: CE, FCC DoC, BCIQ

SAFETY: UL, CSA, TUV

# Switching Power Supply Specifications

Model Name : HPS-300-101

Version :

Issue Date : JUL,31,2000

## 9. Power Good Signal

A TTL compatible signal for the purpose of initiating an orderly start-up procedure under normal input operating conditions. During power up, this signal is asserted ( low ) until +5V is under regulation and AC reaches min. line specification range. After all voltage are going appropriate level, the system may have a turn on delay of 100mS, but no greater than 500mS. During power off the signal should go to low level before +5V is out of regulation. The low level is 0 to 0.8V and high level is 4.75 to 5.25V. The " Power Good "signal can drive up to 6 standard TTL loads.

### Time Diagram

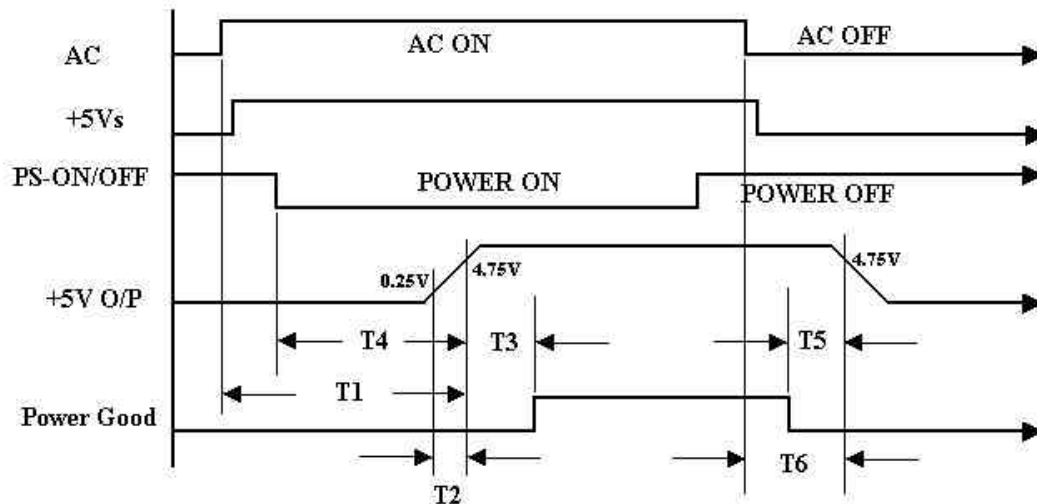

- \* T1 : Turn on time ( 2 sec. Max.)
- \* T2 : Rise time ( 20mS Max.)
- \* T3 : Power good turn on delay time ( 100 < T3 < 500 mS )
- \* T4 : Switch on time (1 sec. Max.)
- \* T5 : Power good turn off delay time ( 1.0 mS Min.) PS-ON/OFF
- \* T6 : Power hold-on time ( 16 mS Min.)

#### \* Power on-off cycle :

When the power supply is turned off for a minimum of 1.0 sec. and turn on again, the power good signal will be asserted.

# Switching Power Supply Specifications

Model Name : HPS-300-101

Version :

Issue Date :JUL,31,2000

---

## 10. MTBF

Failure of power supply shall not exceed 2% per 1000 hours of operation which translates to a minimum MTBF of 100,000 hours.

## 11. Burn-In

### 11.1 Input Voltage

Applying 220Vac for 230V model, and 110Vac for 115V.

### 11.2 Test Condition

Applying full loads for the power supply in 45 (+/-5) °C chamber for 8 hours.

## 12. Mechanical Specification

### 12.1 Outline Dimension

Please refer the mechanical drawing of HPS-300-101.

### 12.2 Weight

Maximum weight is 2.0 Kgs.

### 12.3 Pin Designation :

AC Input : RONG FENG SS-120 OR EQUIVALENT

PA System Board: MOLEX 39-01-2200 or equivalent

18 AWG standard wire 20 pin connector.

PB, PC, PE, PF: AMP 1-480424-0 or MOLEX 8981-04P or equivalent

18 AWG standard wire 4 pin connector.

PD and PG: AMP 171822-4 or equivalent.

18 AWG standard wire 4 pin connector.

# Switching Power Supply Specifications

Model Name : HPS-300-101

Version :

Issue Date : JUL,31,2000

## 12.3.1 Main Output Pin Assignment

### PA(System Board)

PIN 1	+3.3Vdc	ORANGE
PIN 2	+3.3Vdc	ORANGE
PIN 2	+3.3V POSITIVE remote sense	ORANGE
PIN 3	COMMON	BLACK
PIN 4	+5Vdc	RED
PIN 5	COMMON	BLACK
PIN 6	+5Vdc	RED
PIN 7	COMMON	BLACK
PIN 7	+3.3V NEGATIVE remote sense	BLACK
PIN 8	POWER GOOD	GRAY
PIN 9	+5Vs	PURPLE
PIN 10	+12Vdc	YELLOW
PIN 11	+3.3Vdc	ORANGE
PIN 12	-12Vdc	BLUE
PIN 13	COMMON	BLACK
PIN 14	P.S-on	GREEN
PIN 15	COMMON	BLACK
PIN 16	COMMON	BLACK
PIN 17	COMMON	BLACK
PIN 18	-5Vdc	WHITE
PIN 19	+5Vdc	RED
PIN 20	+5Vdc	RED

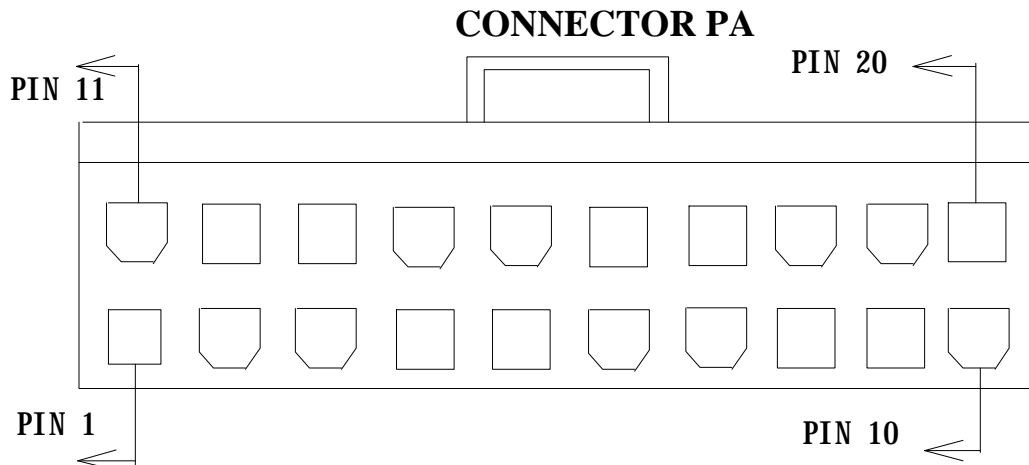

# Switching Power Supply Specifications

Model Name : HPS-300-101

Version :

Issue Date :JUL,31,2000

---

PB, PE

5.25" DISK DRIVE

PIN 1	+12Vdc	YELLOW
PIN 2	COM	BLACK
PIN 3	COM	BLACK
PIN 4	+5Vdc	RED

PC, PF

Daisy Chain

PIN 1	+12Vdc	YELLOW
PIN 2	COM	BLACK
PIN 3	COM	BLACK
PIN 4	+5Vdc	RED

PD, PG

(3.5" DISK DRIVE)

PIN 1	+5Vdc	RED
PIN 2	COM	BLACK
PIN 3	COM	BLACK
PIN 4	+12dc	YELLOW