

Table of Contents

1. General

1.1 Scope

2. Input Characteristics

2.1 Input Voltage

2.2 Input Frequency

2.3 Max. Input AC Current

2.4 Inrush Current

2.5 Efficiency

3. Output characteristics

3.1 Normal Operation Output

3.2 Remote On/Off controlled mode

3.3 Regulation

3.4 Rise Time

3.5 Hold-up Time

4. Protection

4.1 Input Protection

4.2 Output Protection

5. Start Stability

5.1 No Load Start

5.2 Cold Start

6. Environments

6.1 Temperature and Humidity

6.2 Altitude

6.3 Vibration and Shock

7. Conducted EMI

8. Product Safety

- 8.1 Safety Requirement
- 8.2 Leakage Current
- 8.3 Insulation Resistance
- 8.4 Dielectric Voltage Withstand
- 8.5 Certificate and Report

9. Power Good Signal

10. Fan Speed Control

11. MTBF

12. Burn-In

- 12.1 Input Voltage
- 12.2 Test Condition

13. Mechanical Specification

- 13.1 Outline Dimension
- 13.2 Weight
- 13.3 Pin Assignment

1. General

1.1 Scope

This specification defines the general design and performance requirements for SI-C145M2 switching power supply . This model also meet INTEL SPS ATX 2.01 standard request.

2. Input Characteristics

2.1 Input Voltage

Nominal Voltage	Voltage Variation Range
-----	-----
115 Vrms	90 - 132 Vrms
230 Vrms	180 - 264 Vrms

* The power supply is designed to operate in two specified voltage range depending upon outside manual input voltage switch selected. Unless specified the SI-C145M2 shall be set at 230Vac.

2.2 Input Frequency

Nominal Frequency	Frequency Variation Range
-----	-----
50/60 Hz	47 Hz to 63 Hz

* Waveform harmonic distortion will be less than 5%.

* The power supply must operate at above frequency with both 90-132/180-264 Vrms input voltage range.

2.3 Max. Input AC Current

Max. Input Current	Measuring Range
-----	-----
4.0 A	90-132 Vrms
2.0 A	180-264 Vrms

2.4 Inrush Current

Less than the ratings of its critical components (Including bulk rectifiers, fuses and surge limiting device).

2.5 Efficiency

SI-C145M2 provides an efficiency of 65 % minimum when measured at full load under 115V/60Hz and 230V/50Hz. condition.

3. Output characteristics

3.1 Normal Operation Output (LABEL SPEC)

Output Voltage	Load Range MIN MAX	Regulation	Ripple&Noise Peak-to-Peak Max.	Ripple Peak- to-Peak Max.
1. +5V	1.5A 15.0A	+5% ~ -5%	100 mV	50 mV
2. +12V	0.2A 3.0A	+5% ~ -5%	200 mV	120 mV
3. -12V	0.0A 0.5A	+10% ~ -10%	200 mV	120 mV
4. +5Vs	0.0A 1.5A	+5% ~ -5%	100 mV	50 mV
6. +3.3V	0.3A 12.0A	+5% ~ -5%	100 mV	50 mV

*. +5V & +3.3V combined load should not exceed 100W

NOTE:

1. Noise test should be measured with 20 MHz bandwidth frequency oscilloscope. The output terminal shall add a tantalum capacitor of 10uF in parallel with a ceramic capacitor of 0.1uF.

3.2 Remote On/Off Controlled mode

When AC power present, the power supply shall be in save mode operation and +5V S.B shall within its regulation window. When there comes a TTL "L" signal inserted, the power supply shall be on. When TTL signal "H" is inserted the power supply shall be off.

TTL level "H" 3.0V - 5.5V
 "L" 0.0V - 0.8V

3.3 Regulation

The cross regulation defined as follows, the output regulation should be within the specified range.

Load	SYM	+5V	+3.3V	+12V	-12V
ALL Max.	HHHH	12.0A	12.0A	3.0A	0.5A
ALL Min.	LLLL	1.0A	0.3A	0.2A	0.0A
+5V Middle others Min	MLLL	10.0A	0.3A	1.0A	0.0A
+5V Middle others Max.	MHHH	5.0A	12.0A	3.0A	0.5A

3.4 Rise Time

DC output rise time is less than 100 mS at nominal line and full load.

3.5 Hold-up Time

DC +5V output maintains at least 16mS after power off which hold within para 3.1.

4. Protection

4.1 Input Protection

In primary circuit of the power supply , a protected fuse is inserted. Only internal fault of the power supply will cause the fuse blown. Any overload or short circuit at DC output will keep from fuse brown or fire hazard.

4.2 Output Protection

4.2.1 Over Voltage Protection

The +5V/+12V DC output are protected against the over voltage condition . Maximum value can't be over 6.8V at 5V terminal and 15.6V at 12V.

4.2.2 Over Power Protection

The power supply can be used electronic circuit to limit the output current against exceeding 60% of surge output power or protected against excessive power delivery since short circuit of any output or over total power at nominal line.

4.2.3 Short Circuit Protection

Short circuit placed on any DC output will shut down all DC outputs and latch.

5. Start Stability

5.1 No Load Start

When power is applied to SI-C145M2 with no load connected or under minimum load connected, neither damage to power supply nor hazards to users will occur.

5.2 Cold Start

The power supply shall operate properly when first applied after 8 hours storage in 10°C environment.

6. Environments

6.1 Temperature and Humidity

6.1.1 Operating

Temperature 10 to 50 °C

Relative Humidity 20 to 90 %

6.1.2 Storage

Temperature -40 to 60 °C

Relative Humidity 20 to 95 % noncondensing

6.2 Altitude

The power supply can operate normally at any altitude between 0 to 8000 feet.

6.3 Vibration and Shock

Sweep and resonance search for each of X,Y,Z, axis at the sweep.

RATE of 1/OCTAVE/Min.

Frequency	Duration	Amplitude
5 - 20 Hz	15 minutes	0.38 mm
20 - 250 Hz	15 minutes	0.25G

7. Conducted EMI

The power supply will comply with FCC DOCKET 20780, Part 15 Class B limit for 115Vac input, FTZ 243 Class B for 230 Vac input and VCCI CLASS 2 requirement.

8. Product Safety

8.1 Safety Requirement

The power supply will be recognized under UL Standard 1950 without D3 deviation, certified with CSA standard C22.2 No.234-M90 safety requirements, and type approval with IEC publication 950 with A11 amendments.

8.2 Leakage Current

The AC leakage current is less than 3.5mA when the power supply connect to 254Vac/50Hz .

8.3 Insulation Resistance

The insulation resistance should be not less than 30M ohm after applying of 500VDC for 1 minute.

8.4 Dielectric Voltage Withstand

The power supply shall withstand for 1 minute without breakdown the application of a 60Hz 1500V AC voltage applied between both input line and chassis (20mA DC cut-off current). Main transformer shall similarly withstand 3000Vac applied between both primary and secondary windings for a minimum of one minute.

8.5 Certificate and Report

EMC: CE, FCC DoC, BCIQ

SAFETY: UL, CSA, TUV, Nemko, CB

9. Power Good Signal

A TTL compatible signal for the purpose of initiating an orderly start-up procedure under normal input operating conditions. During power up, this signal is asserted (low) until +5V is under regulation and AC reaches min. line specification range. After all voltage are going appropriate level, the system may have a turn on delay of 100mS, but no greater than 500mS. During power off the signal should go to low level before +5V is out of regulation. The low level is 0 to 0.8V and high level is 4.75 to 5.25V. The " Power Good "signal can drive up to 6 standard TTL loads.

Time Diagram

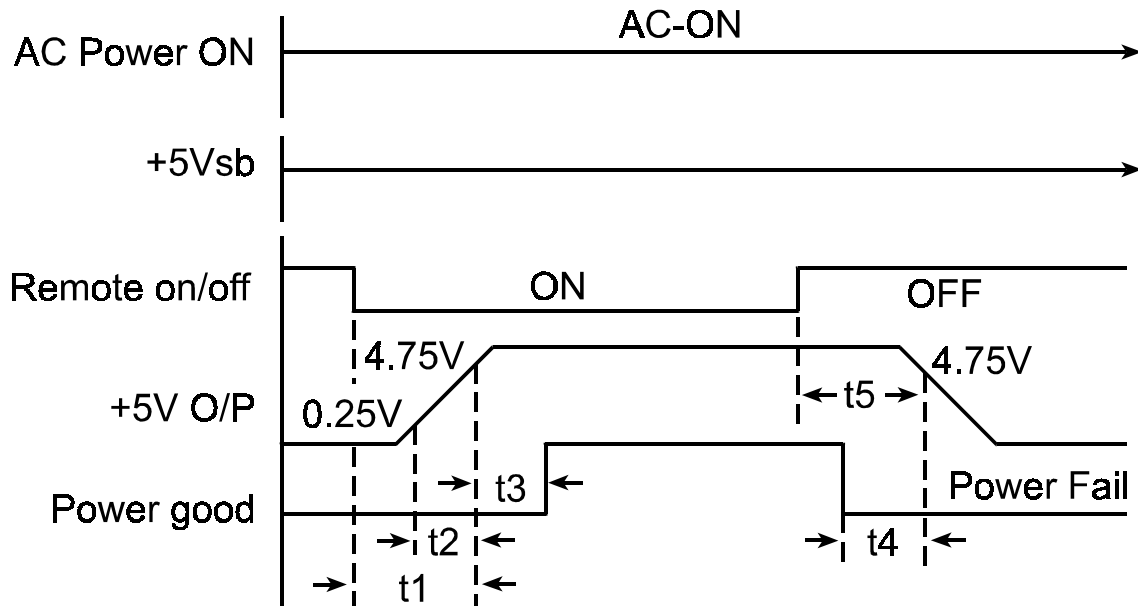

- * t1 : Switch on time (1 sec. Max.)
- * t2 : Rise time (2 mS < t_2 < 20mS .)
- * t3 : Power good turn on delay time (100 < t_3 < 500 mS)
- * t4 : Power good turn off delay time (1.0 mS Min.)
- * t5 : Power hold-on time (16 mS Min.)

* Power on-off cycle :

When the power supply is turned off for a minimum of 1.0 sec. and turn on again, the power good signal will be asserted.

10. Fan Speed Control

Fan control circuit can change its speed turn by the height of internal temperatur

11. MTBF

Failure of power supply shall not exceed 2% per 1000 hours of operation which translates to a minimum MTBF of 100,000 hours, excludes the life of the fan.

12. Burn-In

12.1 Input Voltage

Applying 220Vac for 230V model, and 110Vac for 115V.

12.2 Test Condition

Applying full loads for the power supply in 45 (+/-5) °C chamber for 8 hours.

13. Mechanical Specification

13.1 Outline Dimension

Please refer the mechanical drawing of SI-C145M2.

13.2 Weight

Maximum weight is 2.0 Kgs.

13.3 Pin Designation :

AC Input : RONG FENG SS-120 OR EQUIVALENT

PA System Board: MOLEX 39-01-2200 or equivalent

20 AWG standard wire 20 pin connector.

PC ,PD and PE: AMP 1-480424-0 or MOLEX 8981-04P or equivalent

20 AWG standard wire 4 pin connector.

PB: AMP 171822-4 or equivalent.

20 AWG standard wire 4 pin connector.

13.3.1 Main Output Pin Assignment

PA(System Board)

PIN 1	+3.3Vdc	ORANGE
PIN 2	+3.3Vdc	ORANGE
PIN 3	COMMON	BLACK
PIN 4	+5Vdc	RED
PIN 5	COMMON	BLACK
PIN 6	+5Vdc	RED
PIN 7	COMMON	BLACK
PIN 7	+3.3V NEGATIVE remote sense	BLACK
PIN 8	POWER GOOD	GRAY
PIN 9	+5Vs	PURPLE
PIN 10	+12Vdc	YELLOW
PIN 11	+3.3Vdc	ORANGE
PIN 11	+3.3V POSITIVE remote sense	ORANGE
PIN 12	-12Vdc	BLUE
PIN 13	COMMON	BLACK
PIN 14	P.S-on	GREEN
PIN 15	COMMON	BLACK
PIN 16	COMMON	BLACK
PIN 17	COMMON	BLACK
PIN 18	-5Vdc	WHITE
PIN 19	+5Vdc	RED
PIN 20	+5Vdc	RED

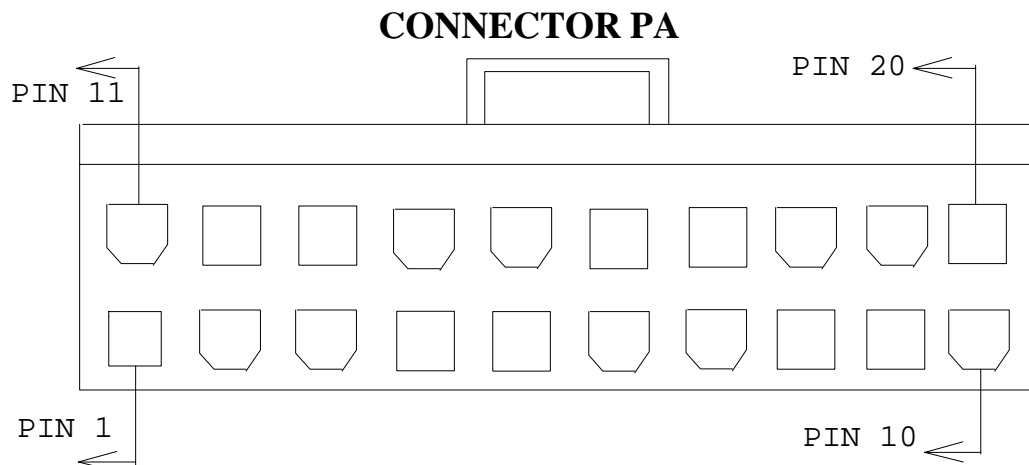

Switching Power Supply Specifications

Model Name : SI-C145M2
Version : C0-B0

PC,PE 5.25" DISK DRIVE

PIN 1	+12Vdc	YELLOW
PIN 2	COM	BLACK
PIN 3	COM	BLACK
PIN 4	+5Vdc	RED

PD Daisy Chain

PIN 1	+12Vdc	YELLOW
PIN 2	COM	BLACK
PIN 3	COM	BLACK
PIN 4	+5Vdc	RED

PB (3.5" DISK DRIVE)

PIN 1	+5Vdc	RED
PIN 2	COM	BLACK
PIN 3	COM	BLACK
PIN 4	+12dc	YELLOW

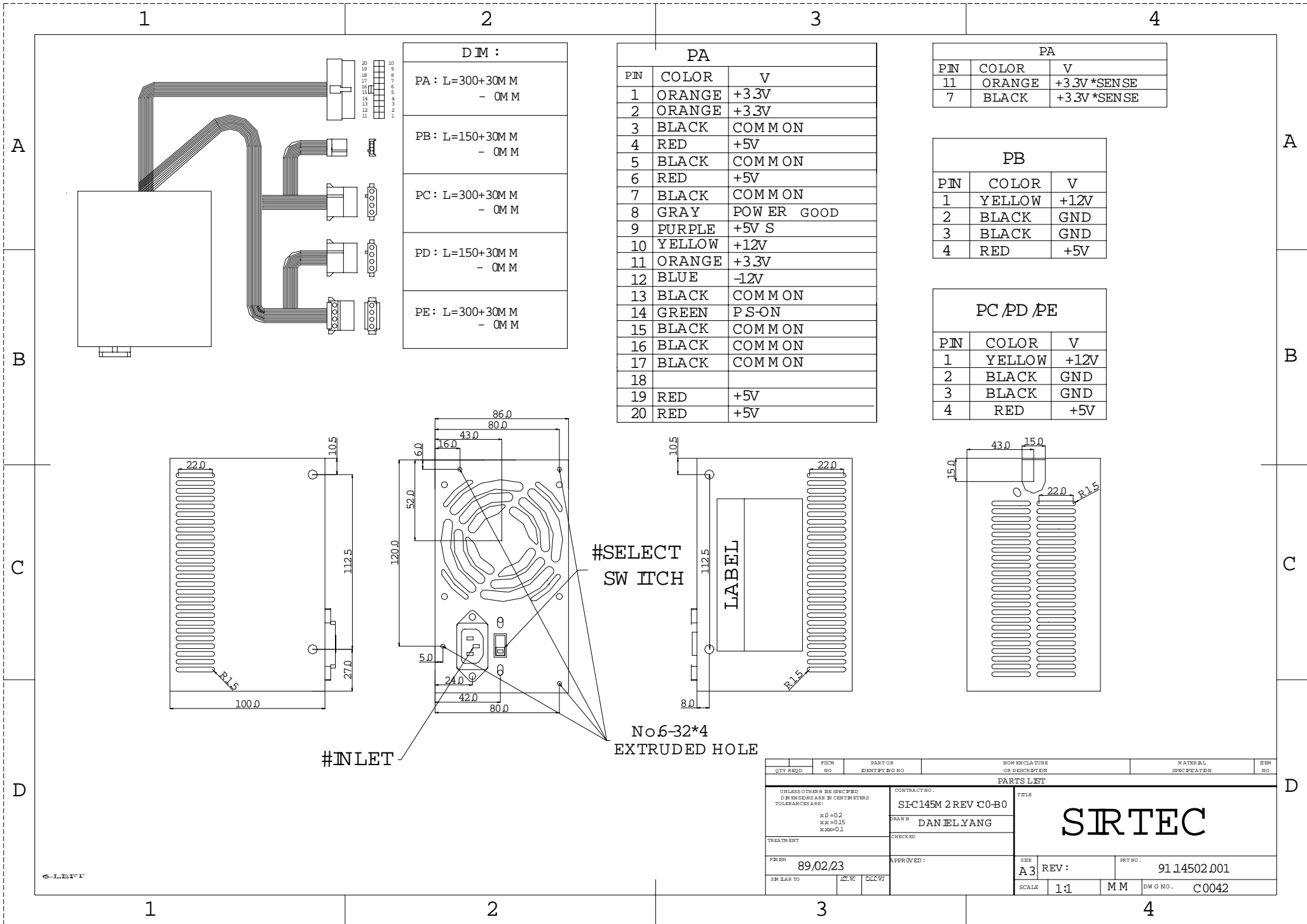

DM :

PA : L=300+30M M - 0M M
PB : L=150+30M M - 0M M
PC : L=300+30M M - 0M M
PD : L=150+30M M - 0M M
PE : L=300+30M M - 0M M

PA

PIN	COLOR	V
1	ORANGE	+3.3V
2	ORANGE	+3.3V
3	BLACK	COMMON
4	RED	+5V
5	BLACK	COMMON
6	RED	+5V
7	BLACK	COMMON
8	GRAY	POWER GOOD
9	PURPLE	+5V S
10	YELLOW	+12V
11	ORANGE	+3.3V
12	BLUE	-12V
13	BLACK	COMMON
14	GREEN	PS-ON
15	BLACK	COMMON
16	BLACK	COMMON
17	BLACK	COMMON
18		
19	RED	+5V
20	RED	+5V

PA

PIN	COLOR	V
11	ORANGE	+3.3V *SENSE
7	BLACK	+3.3V *SENSE

PB

PIN	COLOR	V
1	YELLOW	+12V
2	BLACK	GND
3	BLACK	GND
4	RED	+5V

PC / PD / PE

PIN	COLOR	V
1	YELLOW	+12V
2	BLACK	GND
3	BLACK	GND
4	RED	+5V

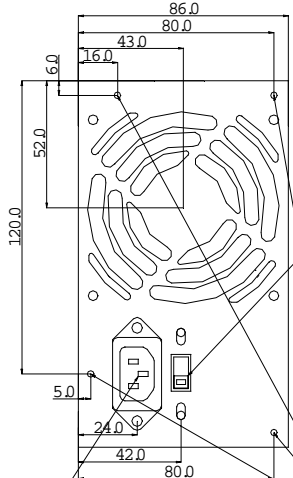
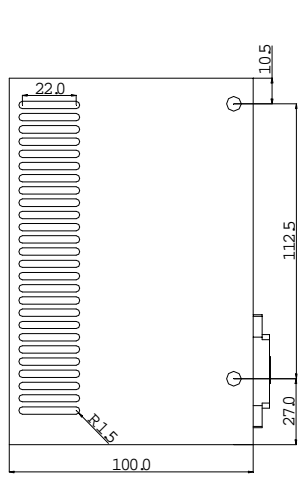

#SELECT SW ITCH

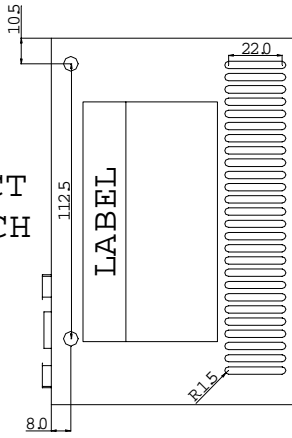

No.6-32*4 EXTRUDED HOLE

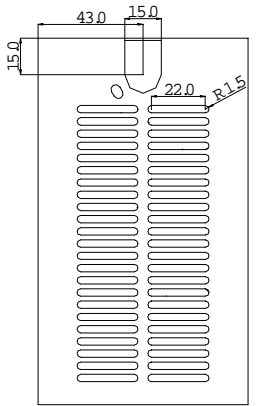

#INLET

QTY REQD	PSM NO	PART OR IDENTIFY NG NO	NOM ENCLATURE OR DESCRPTN	MATERI AL SPECIFCATION	ITEM NO
PARTS LIST					
UNLESS OTHERWISE SPECIFIED DIMENSIONS ARE IN CENTIMETERS TOLERANCES ARE: x0=0.2 xx=0.15 xxx=0.1		CONTRACT NO. SIC145M 2 REV C0-B0		TITLE SIRTEC	
TREATMENT		DRAWN DANIEL YANG		CHECKED	
PDATE 89/02/23		APPROVED:		SCALE A3 REV: 1:1	
DRAWN TO		SCALE		MATERIAL MM DWG NO. C0042	
				PART NO. 91.14502.001	

←LEFT