

# Switching Power Supply Specifications

*Model Name : SI-C200P2 ( ATX-12V )*

*Version :*

*Issue Date : MAR,27,2001*

---

## Table of Contents

### **1. General**

1.1 Scope

### **2. Input Characteristics**

2.1 Input Voltage

2.2 Input Frequency

2.3 Max. Input AC Current

2.4 Inrush Current

2.5 Efficiency

### **3. Output characteristics**

3.1 Normal Operation Output

3.2 Remote On/Off controlled mode

3.3 Regulation

3.4 Rise Time

3.5 Hold-up Time

### **4. Protection**

4.1 Input Protection

4.2 Output Protection

### **5. Start Stability**

5.1 No Load Start

5.2 Cold Start

### **6. Environments**

6.1 Temperature and Humidity

6.2 Altitude

6.3 Vibration and Shock

### **7. Conducted EMI**

# Switching Power Supply Specifications

*Model Name : SI-C200P2 ( ATX-12V )*

*Version :*

*Issue Date : MAR,27,2001*

---

## **8. Product Safety**

- 8.1 Leakage Current
- 8.2 Insulation Resistance
- 8.3 Dielectric Voltage Withstand

## **9. Power Good Signal**

## **10. FanM signal**

## **11. MTBF**

## **12. Burn-In**

- 11.1 Input Voltage
- 11.2 Test Condition

## **13. Harmonics**

## **14. Mechanical Specification**

- 13.1 Outline Dimension
- 13.2 Weight
- 13.3 Pin Assignment

# Switching Power Supply Specifications

Model Name : SI-C200P2 ( ATX-12V )

Version :

Issue Date : MAR,27,2001

---

## 1. General

### 1.1 Scope

This specification defines the general design and performance requirements for SI-C200P2 switching power supply. It also supports remote On/Off control function. Standby voltage and 3.3VDC output which will be the major trend for power supply in future.

## 2. Input Characteristics

### 2.1 Input Voltage

Nominal Voltage	Voltage Variation Range
-----	-----
100 -127 Vrms	90 - 132 Vrms
200 - 240 Vrms	180 – 264 Vrms

\*The power supply is designed Uto operate in two specified voltage range depending upon outside manual input voltage switch selected. Unless specified specified the SI-C200P2 shall be set at 230Vac.

### 2.2 Input Frequency

Nominal Frequency	Frequency Variation Range
-----	-----
50/60 Hz	47 Hz to 63 Hz

\* Waveform harmonic distortion will be less than 5%.

\* The power supply must operate at above frequency with both 90-132/180-264 Vrms input voltage range.

### 2.3 Max. Input AC Current

Max. Input Current	Measuring Range
-----	-----
5.0 A	90-132 Vrms
3.0 A	180-264 Vrms

### 2.4 Inrush Current

Less then the ratings of it`s cirtical components (Including bulk rectifiers.Fuses and surge limiting device).

# Switching Power Supply Specifications

Model Name : SI-C200P2 ( ATX-12V )

Version :

Issue Date : MAR,27,2001

## 2.5 Efficiency

SI-C200P2 provides an efficiency of 65 % minimum when measured at full load under 115V/60Hz and 230V/50Hz. condition.

## 3. Output characteristics

### 3.1

#### a. Normal Operation Output

Output Voltage	Load MIN	Range MAX	Regulation	Ripple&Noise Peak-to-Peak Max.	Ripple Peak-to-Peak Max.
1. +5V	2.0 A	20.0 A	+5% ~ -5%	100 mV	80 mV
2. +12V	0.5 A	8.0 A	+5% ~ -5%	200 mV	120 mV
3. -5V	0.0 A	0.3 A	+10% ~ -10%	200 mV	150 mV
4. -12V	0.0 A	0.5 A	+10% ~ -10%	200 mV	150 mV
5. +5Vs	0.0 A	1.5 A	+5% ~ -5%	100 mV	80 mV
6. +3.3V	0.3 A	14.0 A	+5% ~ -5%	100 mV	80 mV

\*. The max load can't be over 100W when both DC +5V and +3.3V are used.

\*. Maximum continuous total output power shall not exceed 145 watts.

\*. Maximum total peak out power shall not exceed 200 watts.

#### NOTE:

1. Noise test should be measured with 20 MHz bandwidth frequency oscilloscope. The output terminal shall add a tantalum capacitor of 10uF in parallel with a ceramic capacitor of 0.1uF.

### 3.2 Remote On/Off Controlled mode

When AC power present, the power supply shall be in save mode operation and +5V S.B shall within its regulation window. When there comes a TTL "L" signal inserted, the power supply shall be on. When TTL signal "H" is inserted the power supply shall be off.

TTL level "H" 3.0V - 5.5V

"L" 0.0V - 0.8V

### 3.3 Regulation

The cross regulation defined as follows, the output regulation should be within the specified range.

# Switching Power Supply Specifications

Model Name : SI-C200P2 ( ATX-12V )

Version :

Issue Date : MAR,27,2001

Load	SYM	+5V	+3.3V	+12V	-5V	-12V
ALL Max.	HHHHH	12.0A	14.0A	8.0A	0.3A	0.5A
ALL Min.	LLLLL	2.0A	0.3A	0.5A	0.0A	0.0A
+5V Middle others Min	MLLLL	10.0A	0.1A	1.0A	0.0A	0.0A
+5V Middle others Max.	MHHHH	6.0A	14.0A	8.0A	0.3A	0.5A

## 3.4 Rise Time

DC output rise time is less than 20 mS at nominal line and full load.

## 3.5 Hold-up Time

DC +5V output maintains at least 16mS after power off which hold within para 3.1.

## 4. Protection

### 4.1 Input Protection

In primary circuit of the power supply , a protected fuse is inserted. Only internal fault of the power supply will cause the fuse blown. Any overload or short circuit at DC output will keep from fuse brown or fire hazard.

### 4.2 Output Protection

#### 4.2.1 Over Voltage Protection

The +5V/+3.3VDC output are protected against the over voltage condition . Maximum value can't be over 6.8V at 5V terminal and 5.0V at 3.3V.

#### 4.2.2 Over Power Protection

The power supply can be used electronic circuit to limit the output current against exceeding 65% of surge output power or protected against excessive power delivery since short circuit of any output or over total power at nominal line.

#### 4.2.3 Short Circuit Protection

Short circuit placed on any DC output will shut down all DC outputs and latch.

# Switching Power Supply Specifications

Model Name : SI-C200P2 ( ATX-12V )

Version :

Issue Date : MAR,27,2001

---

## 5. Start Stability

### 5.1 No Load Start

When power is applied to SI-C200P2 with no load connected or under minimum load connected, neither damage to power supply nor hazards to users will occur.

### 5.2 Cold Start

The power supply shall operate properly when first applied after 8 hours storage in 10°C environment.

## 6. Environments

### 6.1 Temperature and Humidity

#### 6.1.1 Operating

Temperature 10 to 50 °C

Relative Humidity 20 to 90 %

#### 6.1.2 Storage

Temperature -40 to 60 °C

Relative Humidity 20 to 95 % noncondensing

### 6.2 Altitude

The power supply can operate normally at any altitude between 0 to 8000 feet.

### 6.3 Vibration and Shock

6.3.1 Sweep and resonance search for each of X,Y,Z, axis at the sweep.

RATE of 1/OCTAVE/Min.

Frequency	Duration	Amplitude
5 - 20 Hz	15 minutes	0.38 mm
20 - 250 Hz	15 minutes	0.25G

## 7. Conducted EMI

The power supply will comply with FCC DOCKET 20780, Part 15 Class B limit for 115Vac input, FTZ 243 Class B for 230 Vac input and VCCI CLASS 2 requirement.

---

# Switching Power Supply Specifications

*Model Name : SI-C200P2 ( ATX-12V )*

*Version :*

*Issue Date : MAR,27,2001*

---

## **8. Product Safety**

### **8.1 Leakage Current**

The AC leakage current is less than 3.5mA when the power supply connect to 254Vac/50Hz .

### **8.2 Insulation Resistance**

The insulation resistance should be not less than 30M ohm after applying of 500VDC for 1 minute.

### **8.3 Dielectric Voltage Withstand**

The power supply shall withstand for 1 minute without breakdown the application of a 60Hz 1500V AC voltage applied between both input line and chassis (20mA DC cut-off current). Main transformer shall similarly withstand 3000Vac applied between both primary and secondary windings for a minimum of one minute.

# Switching Power Supply Specifications

Model Name : SI-C200P2 ( ATX-12V )

Version :

Issue Date : MAR,27,2001

## 9. Power Good Signal

A TTL compatible signal for the purpose of initiating an orderly start-up procedure under normal input operating conditions. During power up, this signal is asserted ( low ) until +5V is under regulation and AC reaches min. line specification range. After all voltage are going appropriate level, the system may have a turn on delay of 100mS, but no greater than 500mS. During power off the signal should go to low level before +5V is out of regulation. The low level is 0 to 0.8V and high level is 4.75 to 5.25V. The " Power Good "signal can drive up to 6 standard TTL loads.

### Time Diagram

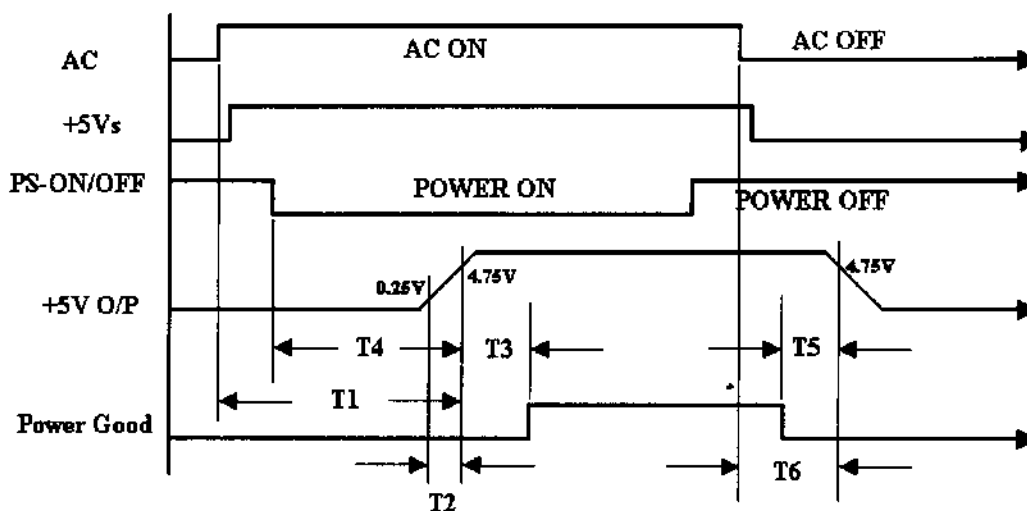

\* T1 : Turn on time ( 2 sec. Max.)

\* T2 : Rise time (  $\leq$  20mS Max.)

\* T3 : Power good turn on delay time (  $100 < T3 < 500$  mS )

\* T4 : Switch on time (1 sec. Max.)

\* T5 : Power good turn off delay time ( 1.0 mS Min.) PS-ON/OFF

\* T6 : Power hold-on time ( 16 mS Min.)

\* Power on-off cycle :

When the power supply is turned off for a minimum of 1.0 sec. and turn on again, the power good signal will be asserted.

# Switching Power Supply Specifications

Model Name : SI-C200P2 ( ATX-12V )

Version :

Issue Date : MAR,27,2001

## 10. FanM signal

The FanM signal is an open collector, 2 pulse per revolution tachometer signal from the power supply fan. The signal stops cycling during a lock rotor state; the level can be either high or low. This signal allows the system to monitor the power supply for fan speed or failures. Implementation of this signal would allow a system designer to gracefully power down the system in the case of a critical fan failure. The monitoring circuit on the motherboard should use a 1k Ohm to 10k Ohm pullup resistor for this signal. The output should be fed into a high impedance gate for the motherboard implementation. Figure 13 shows a simple illustration of the basic circuit requirements. If this signal is not implemented on the motherboard, it should not impact the power supply function.

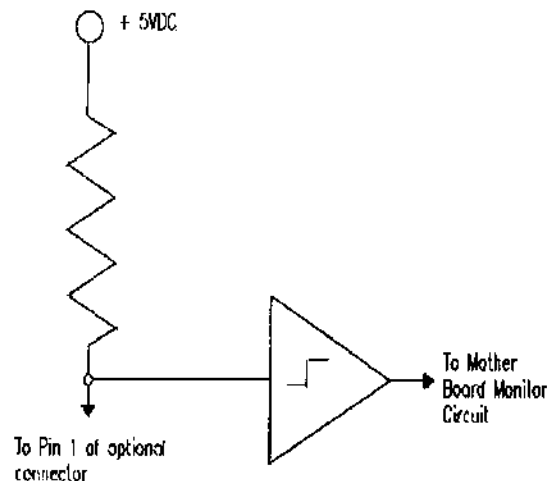

## 11. MTBF

The MTBF of the power should be 100,000 hrs min. Under the conditions as below.

- 1 Input Voltage : 110/220Vac  $\pm$  10%
- 2 Load : 75% of Max Load.
- 3 Enviromental temperature : 25 degree C .

## 12. Burn-In

### 12.1 Input Voltage

Applying 220Vac for 230V model, and 110Vac for 115V.

### 12.2 Test Condition

Applying 75% loads for the power supply in 45 (+/-5) °C<sub>2</sub> chamber for 4 hours.

# Switching Power Supply Specifications

Model Name : SI-C200P2 ( ATX-12V )

Version :

Issue Date : MAR,27,2001

---

## 13. Harmonics

The product shall meet requirement for EN61000-3-2 & EN61000-3-3 :1995 standard of class D, test at 100Vac 50Hz.

## 14. Mechanical Specification

### 14.1 Outline Dimension

Please refer the mechanical drawing of SI-C200P2.

### 14.2 Weight

Maximum weight is 2.0 Kgs.

### 14.3 Pin Designation :

#### 14.3.1 DC CONNECTOR REQUIREMENTS

List or recognized component appliance wiring material(AVLV2) , CN , rated min 85°C , 300VAC shall be used for all output wiring. .

#### 14.3.2

P3

Housing : WST P/N P3-125004

Terminal : WST P/N 125004PS-2

Pin	Signal	28 AWG Wire
1	GND	Black
2		
3	FAN M Signal	Yellow

# Switching Power Supply Specifications

Model Name : SI-C200P2 ( ATX-12V )

Version :

Issue Date : MAR,27,2001

## 14.2.3 BASEBOARD CONNECTOR

PA.

Connector : MOLEX 39-01-2200 or Approved Equivalent

20AWG Wire	Signal	Pin	Pin	Signal	20 AWG Wire
Orange	+3.3 VDC	11	1	+3.3 VDC	Orange
Orange(24AWG)	+3.3V Positive	11	2	+3.3 VDC	Orange
	remote sense		3	COM	Black
Blue	-12 VDC	12	4	+5 VDC	Red
Black	COM	13	5	COM	Black
Green	PS-ON	14	6	+5 VDC	Red
Black	COM	15	7	COM	Black
Black	COM	16	7	+3.3V Negative	Black (24AWG)
Black	COM	17		remote sense	
White	-5 VDC	18	8	POK	Gray
Red	+5 VDC	19	9	+5 Vsb	Purple
Red	+5 VDC	20	10	+12 VDC	Yellow

## 14.2.4 Peripheral Connectors

PC,PD,PF,PG

Connector : AMP 1-480424-0 or MOLEX 8981-04P or approved equivalent

Contacts : AMP 61314-1 terminals or equiv

PB,PE

Connector : AMP 171822-4 or approved equivalent

Pin	Signal	18 AWG Wire	Pin	Signal	22 AWG Wire
1	+12 VDC	Yellow	1	+5 VDC	Red
2	COM	Black	2	COM	Black
3	COM	Black	3	COM	Black
4	+5 VDC	Red	4	+12 VDC	Yellow

## 14.3.5 Auxiliary Power Connector

P6

Connector : Molex 90331-0010 or equivalent

## 14.3.6 +12V Power Connector

P4

Connector : Molex 39-01-2040 or equivalent

Pin	Signal	18 AWG Wire	Pin	Signal	18 AWG Wire
1	COM	Black	1	COM	Black
2	COM	Black	2	COM	Black
3	COM	Black	3	+12VDC	Yellow
4	+3.3 VDC	Orange	4	+12VDC	Yellow
5	+3.3 VDC	Orange			
6	+5 VDC	Red			